

MAVOWATT[®] 50

Energy and Power Disturbance Analyzer

3-349-342-03
3/02.06

- 8 isolated measuring circuits (4 each for voltage and current) with simultaneous sampling (100 kHz, 16 bit)
- Menu driven operation and display of measurement data at a color LCD touch-screen (5½", 320 x 240 pixels)
- Numeric and graphic display modes (scope, vector, table, Y-t recorder, bar graph)
- Power and energy analysis for mains supply and onboard electrical systems (DC, 15 to 1000 Hz), or at the output of frequency converters
- Registration of power disturbances with simultaneous recording of up to 1000 measured quantities and 4 binary signals
- Harmonic analysis up to the 50th harmonic including sub-harmonics (e.g. signalling voltages) in accordance with EN 61000-4-7
- Flicker analysis in accordance with EN 61000-4-15
- Voltage quality evaluation per EN 50160 based upon measuring procedures in accordance with EN 61000-4-30
- Long-term recording to integrated flash memory, unlimited expandability with plug-in storage media (CF cards, USB memory sticks, USB hard disks)
- High speed communication interfaces:
 - USB interfaces for PC, external data memory
 - Ethernet 10/100 with integrated web server for remote control and query via Internet browser
- Power supply output for active current sensors
- Broad range power pack: 85 to 250 V AC/DC with integrated battery



Range of applications

Energy Technology

- Measurement in low and medium-voltage systems* including features for evaluating power quality indices
- Measurement and recording of electrical operating parameters for wind turbine generator systems together with wind speed*
- Measurement and recording of electrical operating parameters for photovoltaic energy systems together with light intensity*

Building Services and Operations Technology

- Acquisition and recording of mains power anomalies for the clarification of interference in the electrical installation and at power consumers
- Recording and analysis of start-up and operating performance of standby generating plants
- Measuring and recording of characteristic electrical quantities for dimensioning static VAR compensators, and testing it for correct functioning
- Load and energy consumption measurements in electrical distribution systems or at operating equipment for the detection of critical operating states or potential energy cost-savings

Electrical Engineering

- EMC testing of electrical devices and systems, including harmonics and flicker
- Measurement of static and dynamic alternating and direct current quantities at electrical/electronic products in R&D, manufacturing, the test lab and for service applications

Drive Technology

- Power measurements at electrical motors with simultaneous recording of mechanical quantities such as RPM, torque, pump pressure or flow rate*
- Determination of characteristic motor values during operation with a frequency converter

Vehicle and Aircraft Manufacturing, Shipbuilding

- Measurements at generators and power consumers in DC automotive electrical systems
- Power and harmonics measurements in locomotives and railway electrical systems
- Power and harmonics measurements for onboard electrical systems in aircraft and ships

* In combination with suitable, upstream measuring transducers

MAVOWATT® 50

Energy and Power Disturbance Analyzer

Function and Range of Applications

The MAVOWATT 50 energy and power disturbance analyzer measures electrical quantities in DC systems, as well as in single and three-phase AC systems with any load.

Broadband, 8-channel measurement is laid out for frequencies of up to 40 kHz, and covers everything from railway power at 16.7 Hz to mains power with 50 or 60 Hz, right on up to onboard electrical systems with up to 1 kHz. Thanks to a filter which can be additionally activated, measurements can also be performed at the outputs of frequency converters.

In addition to the "usual" measured quantities such as voltage, current, frequency, power and energy, the instrument also determines and records all quantities required in order to evaluate power quality in accordance with EN50160 such as harmonic distortion, harmonics and sub-harmonics, as well as flicker intensity and voltage unbalance. Mains disturbances such as dips, interruptions and temporary or transient over-voltages (as of a duration of 10 μ s) can be acquired with a time resolution of 10 ms, and can be recorded along with their characteristic values.

Simultaneous, continuous recording of up to 1000 measured quantities, which can be selected from any of the measuring functions, is possible at intervals ranging from 0.2 seconds to 2 hours. Internal, non-volatile data memory can be expanded in a practically unlimited fashion with plug-in data storage media.

Measured or saved data and evaluations can be displayed in various numeric and graphic views at the instrument's color touch-screen, which can also be used for menu-driven instrument operation. The instrument can also be remote controlled by means of an integrated web server from a PC or via Ethernet/Internet. An Internet browser, for example the Microsoft Internet Explorer, is all that's required for visualization of the user interface. Specific application software for further analysis of recorded measurement data is currently in preparation.

The instrument's broad spectrum of possible applications extends from acquisition, display and recording of mains quantities to registration and analysis of energy consumption, right on up to calculation and statistical analysis of the voltage characteristics in electricity distribution systems in accordance with EN 50160.

In industrial applications, the precision measuring instrument is used to determine characteristic quantities of electrical consumers and generators in steady-state, as well as during dynamic processes.

Its compact, rugged design and universal power supply options make the MAVOWATT 50 suitable for stationary operation, as well as mobile applications all over the world.

Features and Characteristics

Eight Mutually Isolated Measurement Inputs

The MAVOWATT 50 is equipped with eight isolated measuring circuits (4 each for voltage and current) for simultaneous measurement of phase and neutral conductor voltage and current. By connecting a suitable measuring transducer, the fourth channel can be used alternatively for acquiring other physical quantities, e.g. the temperature of a motor or transformer, or wind speed at a wind power turbine. Mutual isolation of the measuring channels provides for enhanced operating safety and prevents circulating currents, or allows for simultaneous measurement in two separate electrical circuits, e.g. at the input and the output of a rectifier.



- Four analog **voltage measurement inputs**, namely U_{L1} , U_{L2} , U_{L3} and U_{L4} , for direct or alternating voltages of up to 900 V (measuring category III) or 600V@CAT III / 300V@CAT IV). Measurements in medium-voltage systems can be performed by means of voltage transformers at the system side. Their transformation ratios can be set individually for each input.
- Four analog **current measurement inputs**, namely I_{L1} , I_{L2} , I_{L3} and I_{L4} , laid out as voltage inputs (see *Technical Data* for measuring ranges) for connecting shunts or (clip-on) current transformers with voltage output. If flexible current sensors are utilized (Rogowski coils), a 9 V voltage output can be used to supply them with power. The transformation ratio can be set individually for each input.

Eight Digital Status and Control Inputs

- Four binary **status inputs**, namely **a**, **b**, **c** and **d**, for displaying and recording ON/OFF statuses, for example the operating states of machines, equipment and alarm devices. The inputs are equipped with a common floating reference point, and are S_0 compatible (max. 30 V).
- Four binary **control inputs**, namely **e**, **f**, **g** and **h**, for controlling device functions, for example starting / stopping recordings. These are also floating inputs, and are TTL compatible.

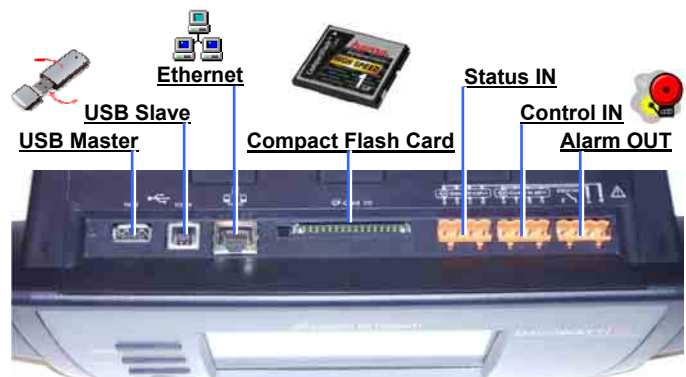

Alarm Output for Limit Value Monitoring

An alarm output is used to indicate limit values which have been exceeded or fallen short of for up to four selectable measured quantities. The output generates a group alarm by switching a floating relay contact.

MAVOWATT® 50

Energy and Power Disturbance Analyzer

Universal Power Supply

The MAVOWATT 50 is supplied with power by means of an internal broad-range variable power pack which requires a line voltage of 85 to 250 V AC/DC.

The instrument can be operated for up to 30 minutes with the integrated rechargeable battery for autonomous use, or in the case of power failure.

Graphic Compatible Color Display

Measurement results and status information, as well as setup menus, operating instructions and schematic diagrams are displayed at the highly luminous, color LCD touch-screen.

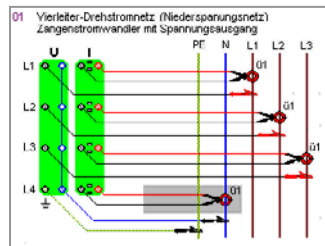

Easy Operation

Manual instrument operation is accomplished primarily via the LCD touch-screen. Functions and displays are selected, and operating modes and parameters are set with the help of context menus. Frequently used operating functions can be directly executed by means of four additional keys (ON|MENU, HELP, ESC, PRINT), for example saving the display image as a bitmap file to an interconnected USB data storage medium. Measuring parameters and device settings remain unchanged when the instrument is switched off.

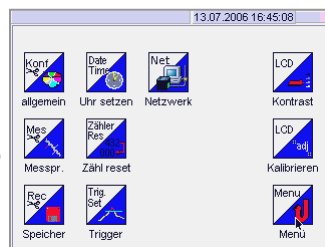

Auswahl: Messprofil		15.04.2005 10:23:05
Profilname		Messprofil 1
Iratio Phase 1		20
Iratio Phase 2		1
Iratio Phase 3		1
Iratio Phase 4		1
Bereich I Phase 1		300 mV
Bereich I Phase 2		3 V
Bereich I Phase 3		3 V
Bereich I Phase 4		3 V

One of two different languages can be selected in the operating menus (standard languages: English and German). Additional language versions (French, Italian, Spanish) are available as software modules and can be uploaded to the instrument via the PC interfaces.

Highly Accurate Real-Time Clock

In particular the acquisition of mains disturbances necessitates an exact record of the time at which the event occurred. However, at most locations where mains analyzers are used, receiving GPS or DCF77 signals for the purpose of time synchronization is either not possible at all, or only possible at considerable expense.

The MAVOWATT 50 is equipped with a highly accurate real-time clock to this end with a time resolution of 10 ms and a drift of no greater than 5 seconds per month.

One of the following date formats can be selected:

- DD.MM.YYYY
- YYYY-MM-DD
- MM/DD/YYYY



Saving Measuring Parameters and Measurement Results

The MAVOWATT 50 is equipped with an internal, non-volatile flash memory module, to which measurement results and applications specific device settings (measuring and memory profiles) can be saved as data files.

Beyond this, all of the files can also be saved to a plug-in CF card (compact-flash memory card), or to any data storage medium connected to the USB port (memory stick, USB hard disk). Data media can also be interchanged during recording, because data are stored to buffer memory inside the instrument.

Up to 1000 measured quantities can be selected from all of the measuring functions for simultaneous recording, and can be registered in a time-triggered, as well as an event-triggered fashion.

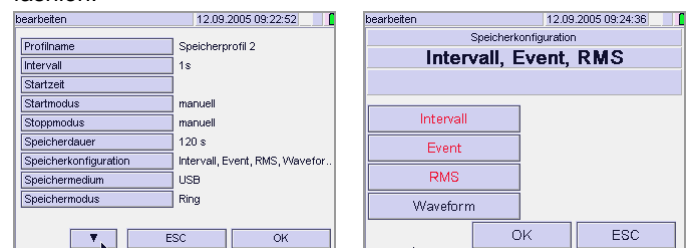

Momentary measurement data for all measuring functions can be displayed independent of the currently running recording function.

Recorded measured data can be displayed either graphically or alphanumerically. Transmission of the measurement data file to a PC and evaluation with the help of specific analysis software (in preparation as accessory) is advisable for long-term recordings.

MAVOWATT[®] 50

Energy and Power Disturbance Analyzer

Measuring Functions

The MAVOWATT 50 places a total of about 3000 different measured quantities and evaluations at the disposal of the user. These are distributed amongst a variety of function-specific and application-specific menus.

In addition to this, it is also possible to define five individualized selections, within which up to any 1000 measured quantities and evaluations can be assembled from all of the measuring functions.

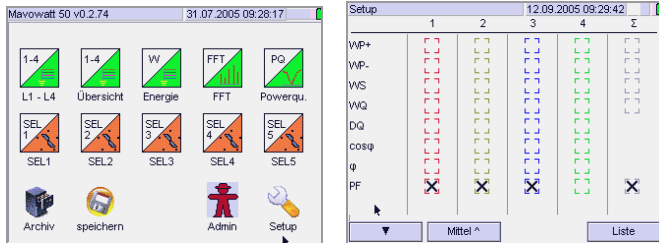

Power and Energy Measurements

This function provides all of the required measured values for comprehensive power and energy analysis – individually for each phase, and for the entire system. Various alphanumeric and graphic display modes are available for displaying measured values and measurement series:

List

L1	U1	I1	P1	f1	S1	Q1	PF1	cosφ1
U1	236,0 V							
I1		2,407 A						
P1			0,280k W					
f1				49,98 Hz				
S1					0,568k VA			
Q1						0,494k var		
PF1							0,493	
cosφ1								0,975

Matrix

L1-L4	L1	L2	L3	L4	Σ
U	229,8	229,8	229,8	0,0	398,1 V
I	0,251	0,51	0,400	0,000	693,7 mA
P	54,2	0,110k	86,4	0,0	250,1 W
f	50,00	50,00	50,00	0,00	50,00 Hz
S	57,7	0,118k	91,9	0,0	276,2 VA
Q	19,7	0,039k	31,5	0,0	117,2 var
PF	0,940	0,941	0,939	0,000	0,003
UΔ	398,1	398,2	398,1		V

Table

Zeit	P1	f1	S1	Q1	PF1	cosφ1
08:49:10	27,0	49,98	58,2	51,6	0,463	0,978
08:49:09	27,0	49,99	58,3	51,6	0,463	0,978
08:49:08	26,9	49,99	58,2	51,6	0,462	0,979
08:49:07	27,0	49,98	58,3	51,7	0,463	0,979
08:49:06	27,0	49,99	58,2	51,6	0,463	0,978
08:49:05	27,1	49,98	58,3	51,7	0,464	0,978
08:49:04	27,0	49,98	58,3	51,7	0,463	0,978
08:49:03	26,9	49,99	58,3	51,7	0,461	0,979
08:49:02	26,9	49,98	58,3	51,7	0,462	0,979
08:49:01	26,9	49,98	58,3	51,7	0,462	0,979
08:49:00	27,0	49,98	58,3	51,7	0,463	0,979
08:48:59	26,9	49,99	58,3	51,7	0,463	0,979
08:48:58	27,0	49,99	58,3	51,7	0,463	0,979

Min/Max

L1-Statistik	L1	min	max
U	238,6	52,7	240,2 V
I	6,86	0,00	7,42 A
P	0,348k	-0,012k	0,380k W
f	50,02	33,33	3,387k Hz
S	1,637k	0,000k	1,758k VA
Q	1,600k	0,000k	1,718k var
PF	0,213	-0,518	0,497
cosφ	0,582		

Scope

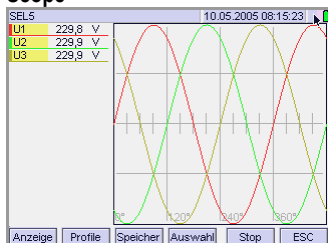

Vector

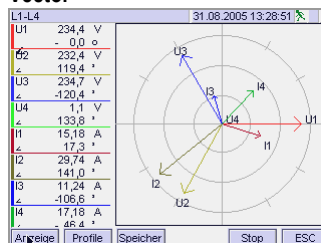

Recorder

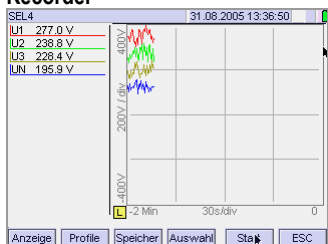

Depending upon the measured quantity and the measuring range, numeric measured values are displayed as 2 to 4-digit figures with floating decimal point, unit of measure and preceding minus sign if applicable. The read-out of measured values takes the selected transformation ratios of the utilized current and voltage transformers into consideration.

The individual phases are differentiated by means of color coding in the graphic displays.

All measured values are acquired every 200 ms, simultaneously and uninterruptedly, synchronized to 10/12 signal periods at 50/60 Hz. They can be recorded as momentary measured values at intervals of 0.2 seconds to 2 hours, or as maximum, minimum and mean values. The display is refreshed once per second.

Special Feature: Measurements at Frequency Converters

Modern electronic frequency converters used for controlling electric motor speed usually have a high frequency square-wave output voltage which is pulse-width modulated via motor frequency. This type of measurement signal requires a special measuring process, by means of which the converter switching frequency is filtered out, and the effective modulation frequency at the motor (fundamental frequency) is determined. This is accomplished with the MAVOWATT 50 by means of a low-pass filter for the voltage measurement inputs, which can be activated or deactivated. Based upon signals processed in this way, the instrument is then capable of deriving all required measured quantities for power and energy analysis, assuming the following conditions are fulfilled:

- Switching frequency must lie within a range of 1.5 to 30 kHz, and fundamental frequency between 10 and 100 Hz.
- Motor current is acquired in an electrically isolated fashion, e.g. by means of (clip-on) current sensors.

Available Measured Quantities for Power & Energy Measuring Functions

Symbol	Measured Quantity	Unit of Measure	L1	L2	L3	L4	Σ 1-3
Ux	L-N voltage, RMS value	V	•	•	•	•	•
UΔx	L-L voltage, RMS value	V	•	•	•		
Ix	Phase current, RMS value	A	•	•	•	•	•
Px	Active power	W	•	•	•	•	•
Qx	Reactive power	var	•	•	•	•	•
Sx	Apparent power	VA	•	•	•	•	•
DQx	Reactive power compensation for DPF setpoint = 1	var	•	•	•	•	•
WP+x	Active energy import	Wh	•	•	•	•	•
WP-x	Active energy export	Wh	•	•	•	•	•
WQx	Reactive energy	varh	•	•	•	•	•
WSx	Apparent energy	VAh	•	•	•	•	•
cosφx	Displacement power factor	-	•	•	•	•	•
φx	Phase-shift angle	°[degrees]	•	•	•	•	•
PFx	Power factor (P/S)	-	•	•	•	•	•
CFUx	Voltage crest factor	-	•	•	•	•	•
CFIx	Current crest factor	-	•	•	•	•	•
fx	Voltage frequency	Hz	•	•	•	•	•
ux(t)	Voltage waveshape	V	•	•	•	•	•
ix(t)	Current waveshape	A	•	•	•	•	•
Rot	Phase sequence of the 3 voltages	> / <					•

MAVOWATT® 50

Energy and Power Disturbance Analyzer

Spectral analysis (FFT)

The spectral analysis function allows for simultaneous acquisition, analysis and display of harmonics and inter-harmonics for voltage and current up to the 50th harmonic at a fundamental frequency within a range of 16 Hz to 1 kHz.

DC components, fundamental components, harmonics and inter-harmonics are continuously and uninterruptedly determined for each measuring channel by means of the Fast Fourier Transformation process in real-time at all eight channels at an interval of 5 Hz over a 200 ms rectangular window; synchronization to 10 or 12 signal periods is carried out at line frequencies of 50 and 60 Hz respectively.

In accordance with the latest edition of norm IEC/EN 61000-4-7 for harmonics measuring instruments, pure harmonics, as well as harmonic and sub-harmonic groups and sub-groups, can be measured. This not only makes it possible to determine the effects of non-linear power consumers on the supply mains, signalling voltages and other distortions which are not synchronized to the system can be detected as well. These are caused, for example, by arc melting furnaces and frequency converters.

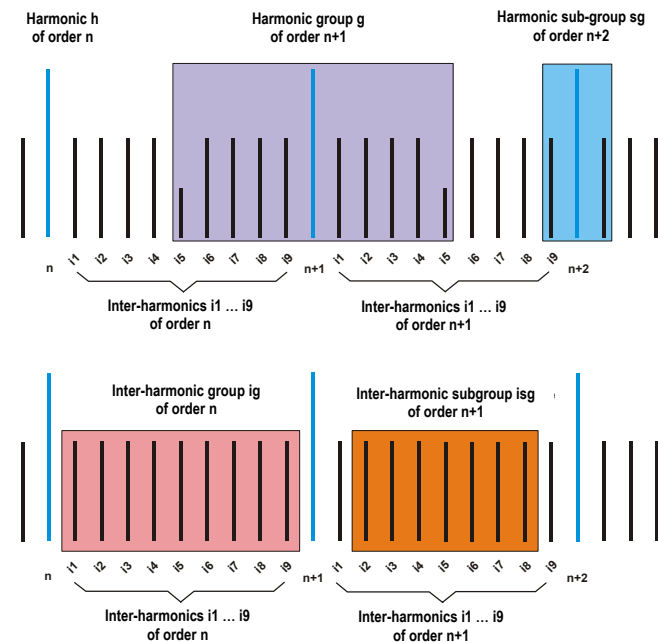

Beyond this, spectral analysis provides us with the phase angle relative to the fundamental component, as well as the measured power value, for each harmonic. Based upon its polarity, conclusions can be drawn regarding the origin of the harmonics.

As a basic analysis, the measured values for respective total harmonic distortion (THD) for voltage and current can be numerically displayed – simultaneously for all four phases.

Partial weighted harmonic distortion (PWHD), as well as group total harmonic distortion (THDG) and subgroup total harmonic distortion (THDS), are represented in the same manner.

A detailed analysis can be conducted based upon graphic or tabular representations.

THD	L1	L2	L3	L4
THD-U	1,6	1,4	1,7	0,0
THDS-U	1,7	1,6	1,7	0,0
THDG-U	0,8	0,8	0,8	0,0
THD-I	3,4	2,1	0,0	3,0
THDS-I	1,9	1,8	2,0	3,0
THDG-I	1,9	1,8	2,0	3,0
PWHD-I	1,0	1,0	0,9	2,1

The graphic representation depicts the frequency spectrum of the harmonics as a bar graph. Alternatively, the measured values for the harmonic or inter-harmonic groups or subgroups can be displayed as a bar-graph. Beyond this, the measured values for a selected bar graph and the basic measured quantity are displayed numerically.

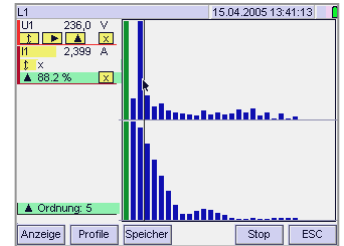

Harmonische	V	%	φ
U1[0]	0,1	0,0	0,0
U1[1]	234,1	100,0	-
U1[2]	0,1	0,0	0,0
U1[3]	1,8	0,8	-70,8
U1[4]	0,0	0,0	0,0
U1[5]	1,1	0,5	-94,7
U1[6]	0,0	0,0	0,0
U1[7]	3,1	1,3	59,1
U1[8]	0,0	0,0	0,0
U1[9]	0,1	0,1	0,0
U1[10]	0,0	0,0	0,0
U1[11]	1,4	0,6	-127,4
U1[12]	0,0	0,0	0,0
U1[13]	0,9	0,4	0,0

Harmonische Gruppe	V	%	φ
U1-HG[0]	0,0	0,0	-
U1-HG[1]	231,2	100,0	-
U1-HG[2]	0,0	0,0	-
U1-HG[3]	1,4	0,6	-
U1-HG[4]	0,0	0,0	-
U1-HG[5]	1,9	0,8	-
U1-HG[6]	0,0	0,0	-
U1-HG[7]	3,3	1,4	-
U1-HG[8]	0,0	0,0	-
U1-HG[9]	0,2	0,1	-
U1-HG[10]	0,0	0,0	-
U1-HG[11]	1,3	0,6	-
U1-HG[12]	0,0	0,0	-
U1-HG[13]	0,9	0,4	-

The tabular view shows the measured values for the above mentioned measured quantities numerically as V/A/W, as well as relative to the fundamental component as a percentage. The phase angle, with reference to the fundamental component, is additionally displayed for the harmonics.

Measured Quantities Available for Spectral Analysis

Symbol	Measured Quantity	Unit of Measure	L1	L2	L3	L4
Ux THD	Total harmonic distortion h2 ... h50 for voltage Ux	%	•	•	•	•
Ux THDG	Group total harmonic distortion hg2 ... hg50 for voltage Ux	%	•	•	•	•
Ux THDS	Subgroup total harmonic distortion sg2 ... sg50 for Ux	%	•	•	•	•
Ux PWHD	Partial weighted harmonic distortion for Ux within an adjustable range from hmin to hmax	%	•	•	•	•
Ux H0	DC voltage component of Ux (absolute and relative to UxH1)	V, %	•	•	•	•
Ux H1	Fundamental voltage of Ux (absolute and relative to UxH1)	V, %	•	•	•	•
Ux H2 ... Ux H50	Voltage of harmonic h2 ... h50 for Ux (absolute and relative to UxH1)	V, %	•	•	•	•
Ux HG1 ... Ux HG50	Voltage of harmonic group hg1 ... hg50 for Ux (absolute and relative to UxH1)	V, %	•	•	•	•
Ux HS1 ... Ux HS50	Voltage of harmonic subgroup hs1 ... hs50 for Ux (absolute and relative to UxH1)	V, %	•	•	•	•
Ux IG1 ... Ux IG49	Voltage of inter-harmonic group ig1 ... ig49 for Ux (absolute and relative to UxH1)	V, %	•	•	•	•
Ux IS1 ... Ux IS49	Voltage of inter-harmonic subgroup is1 ... is 49 for Ux (absolute and relative to UxH1)	V, %	•	•	•	•
Ix THD	Total harmonic distortion h2 ... h50 for current Ix	%	•	•	•	•
Ix THDG	Group total harmonic distortion hg2 ... hg50 for current Ix	%	•	•	•	•
Ix THDS	Subgroup total harmonic distortion sg2 ... sg50 for Ix	%	•	•	•	•
Ix PWHD	Partial weighted harmonic distortion for Ix within an adjustable range from hmin to hmax	%	•	•	•	•

MAVOWATT® 50

Energy and Power Disturbance Analyzer

I_x H0	DC current component of I _x (absolute and relative to I _x H1)	A, %	•	•	•	•
I_x H1	Fundamental current of I _x (absolute and relative to I _x H1)	A, %	•	•	•	•
I_x H2 ... I_x H50	Current of harmonic h2 ... h50 for I _x (absolute and relative to I _x H1)	A, %	•	•	•	•
I_x HG1 ... I_x HG50	Current of harmonic group hg1 ... hg50 for I _x (absolute and relative to I _x H1)	A, %	•	•	•	•
I_x HS1 ... I_x HS50	Current of harmonic subgroup hs1 ... hs50 for I _x (absolute and relative to I _x H1)	A, %	•	•	•	•
I_x IG1 ... I_x IG49	Current of inter-harmonic group ig1... ig49 for I _x (absolute and relative to I _x H1)	A, %	•	•	•	•
I_x IS1 ... I_x IS49	Current of inter-harmonic subgroup is1 ... is49 for I _x (absolute and relative to I _x H1)	A, %	•	•	•	•
P_x H0	DC power component of P _x (absolute and relative to P _x H1)	W, %	•	•	•	•
P_x H1	Fundamental power of P _x (absolute and relative to P _x H1)	W, %	•	•	•	•
P_x H2 ... P_x H50	Power of harmonic h2 ... h50 for U _x (absolute and relative to P _x H1)	W, %	•	•	•	•
φ U_x H0 ... φ U_x H50	Phase angle of harmonic h0 ... h50 for U _x to fundamental voltage U _x H1	°[degrees]	•	•	•	•
φ I_x H0 ... φ I_x H50	Phase angle of harmonic h0 ... h50 for I _x to fundamental current I _x H1	°[degrees]	•	•	•	•

Transient Measurement

The transient measuring function provides options for acquiring and recording very short, transient events as of a duration 10 μs and up to a value of 1300 V_{peak} in alternating and direct voltage systems, as well as at power consumers connected to such systems.

As opposed to the RMS trigger values used in power disturbance analysis, trigger conditions for recording events using the transient measurement function are derived directly from the sampled values of the measuring signals. The time interval between two samplings, and thus the minimum duration of detectable events, can be set within a range of 10 to 655 μs.

When an event is detected, samples of voltage and current values from the relevant phases are saved to memory over an adjustable period of time in consideration of the selected pre-trigger, and appear at the display as a characteristic curve.

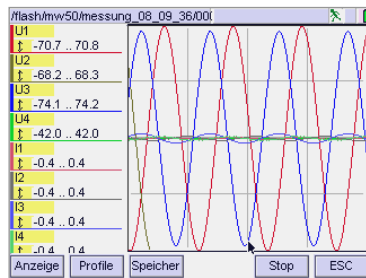

In addition to acquiring sporadic mains voltage interferences, this type of representation is especially well suited for recording current and voltage signal characteristics when power consumers are switched on and off (e.g. motor start-up).

Measured Quantities Available for Transient Measurement

Symbol	Measured Quantity	Unit of Measure	L1	L2	L3	L4	Σ 1-3
u_x(t)	Voltage signal characteristics	V	•	•	•	•	
i_x(t)	Current signal characteristics	A	•	•	•	•	

Flicker Measurement

Flicker measurement is used to determine flicker intensity, as well as associated characteristic values for voltage changes.

Flicker is defined as the subjective impression of luminance fluctuations at lighting fixtures caused by supply voltage changes.

Fluctuations of this sort can be acquired and evaluated with the help of a flicker meter. IEC/EN 61000-4-15 defines the basic functional principle of a flicker meter, which simulates the complex chain of events which takes place at the lamp, the eye and the brain, and which correlates measurement results to an experimentally determined limit value curve (perceptual limits).

Values for the resulting measured quantities including momentary flicker intensity P(t), short-term flicker intensity P_{st} (10 minutes) and long-term flicker intensity P_{lt} (2 hours) are determined simultaneously for all three phase voltages.

These measured values serve as the basis for evaluation of voltage fluctuations in accordance with the standards, for example EN 50160.

Furthermore, the function also acquires the largest relative voltage deviation (d_{max}) which occurs during the short-term measuring interval, relative constant voltage fluctuation (dc) and, for voltage changes of less than 3%, the maximum deviation duration (dt>3%).

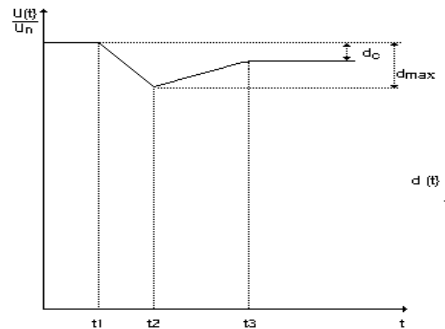

These measured quantities are required for type testing for electrical operating equipment per IEC/EN 61000-3-3.

Adherence the limit values set forth in this standard is required as of the year 2001 for application of the CE mark to electrical and electronic equipment and devices with input current of up to 16 A.

Measured Quantities Available for Flicker Measurement

Symbol	Measured Quantity	Unit of Measure	L1	L2	L3	L4
P(t)_x	Momentary flicker for voltage U _x	-	•	•	•	
P_{stx}	Short-term flicker (10 min.) for voltage U _x	-	•	•	•	
P_{ltx}	Long-term flicker (2 h) for voltage U _x	-	•	•	•	
d_{maxx}	Largest relative voltage deviation	%	•	•	•	
dc_x	Relative constant voltage deviation	%	•	•	•	
dt>3%_x	Maximum duration of deviation dt>3%	s	•	•	•	

MAVOWATT® 50

Energy and Power Disturbance Analyzer

Power Disturbance Logging and Power Quality Analysis per EN 50160 (PQ)

The line voltage quality characteristics specified in EN 50160 can be acquired, calculated and analyzed with the PQ function. EN 50160 describes the respective supply voltage characteristics, and specifies values or value ranges "which may only be exceeded in exceptional cases" during normal operation. The number of times that a limit value is exceeded during a specific period of time is a measure of the quality of electrical supply power.

The MAVOWATT 50 uninterruptedly monitors and evaluates the supply voltage characteristics described in EN 50160. In doing so, the measuring procedures specified in IEC/EN 61000-4-30 are utilized wherever it is possible to conduct evaluation in accordance with EN 50160.

The single period RMS value, which is generated once every half period, is the basic measured value for recording short-term events including voltage dips, swells and interruptions. The other measured values are generated over an interval of 10 periods at 50 Hz, or 12 periods at 60 Hz. Mean values are calculated for durations of 10 seconds (for frequency), 10 minutes (for long-term events such as slow voltage changes and harmonic distortion) and 2 hours (for long-term flicker).

These measured values are continuously compared with the respective, individually adjustable limit values, or the fixed limit values specified for harmonics and flicker, and are recorded as events if appropriate.

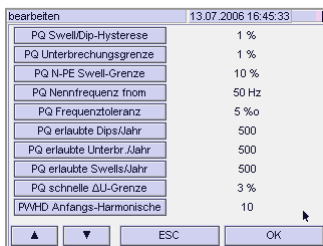

Limit value violations are listed chronologically in the **PQ events list** along with their specific measuring parameters (event type, time, duration, measured value etc.).

Datum / Zeit	Typ	Wert	Dauer
04.06.2005 12:48:51,800	U2 Dip	128,4 V	380 ms
04.06.2005 12:48:50,800	U2 Dip	78,4 V	60 ms
04.06.2005 12:48:40,400	U2 Drop		1,3 s
04.06.2005 12:28:50,000	Uunbal	3,4 %	
04.06.2005 12:27:19,340	UHDwn		49 s
04.06.2005 11:15:40,000	PLT 1	1,3	
04.06.2005 10:21:20,000	U3 HB	4,2 %	

The **PQ statistics matrix** shows the number of events which occurred during the elapsed monitoring period for the respective characteristic for each phase, as well as for the overall system, and places this number in relationship to permissible frequency.

	L1	L2	L3	L13	Σ	%
f	--	--	--	--	1050	6,86
URMS	8	17	20	--	45	89,29
ΔUrap	107	98	232	--	437	
PLT	2	1	2	--	5	68,03
UDips	5	10	20	4	39	79,59
UDrop	30	20	30	90	170	42,50
USwell	30	20	10	4	64	125,49
UAsym	--	--	--	--	6	42,2
UHarm	32	20	40	--	92	182,54
UTHDS	20	25	10	--	55	109,13

The **PQ view (graphic overview)** provides a graphic representation of the above mentioned statistical values in the form of a bar graph, and allows the user to quickly determine which characteristics are not in compliance with the limit values and specifications set forth in EN 50160.

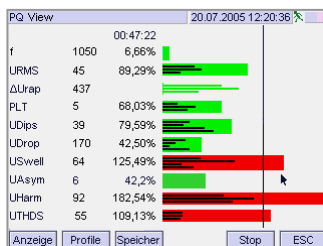

Power Quality Characteristics in Accordance with EN 50160

Characteristic	Requirements	Sampling Interval	Observation Time
Line frequency	f _{nom} ±1% for 99.5% of a given week f _{nom} +4/-6% for 100% of a given week	10 second mean value	1 week
Slow voltage changes	U _{nom} ±10% for 95% of a given week U _{nom} +10/-15% for 100% of a given week	10 minute mean value	1 week
Flicker	Long-term flicker intensity Plt < 1 for 95% of a given week,	2 hours	1 week
Voltage dips (10 ms to 1 min.)	Quantity: <10 to 1000 per year	½ period RMS value	1 week
Short interruptions (<3 min.)	Quantity: <10 to 1000 per year, of which >70% have a duration of <1 s	½ period RMS value	1 year
Long interruptions (>3 min.)	Quantity: <10 to 50 per year	½ period RMS value	1 year
Transient overvoltage	Duration: 1 µs to a few ms, between phase and neutral conductor: <6 kV _s		
Unbalance	Relationship U (negative phase-sequence system) / U (positive phase-sequence system) <2% for 95% of a given week	10 minute mean value	1 week
Harmonics	+UH2 to UH25 < limit value per table for 95% of a given week; THDU(H2-H40) <8% for 95% of a given week	10 minute mean value	1 week
Inter-harmonics	No specified limit values / compatibility level		
Signalling voltage	No specified limit values / compatibility level		

MAVOWATT® 50

Energy and Power Disturbance Analyzer

Technical Data

If not otherwise specified, the following data apply under the listed "ambient conditions" and for a scaling factor of 1.

Specified measuring uncertainties are valid for a calibration interval of 12 months and are fulfilled by the instrument 30 minutes after it has been powered up.

Voltage Measurement Inputs

Characteristic	Specification	Note
Quantity	4	Mutually isolated
Connection	Two 4 mm safety sockets each	Red (high), black (low)
Connection options	Single phase 2-phase (split-phase) 3-phase, wye 3-phase, delta	L1-N, PE-N L1-N, L2-N, PE-N L1-N, L2-N, L3-N, PE-N L1-L2, L2-L3, L3-L1
Input impedance	4 MΩ // 5 pF	
Coupling	AC / AC+DC	
Input range	0 to 150 V / 300 V / 600 V / 900 V	Manually selectable
Scaling factors	0.001 to 99,999 V/V	Individually adjustable for each input
Overload withstand	Continuous: 1200 V _{RMS} , transient (1.2/50 μs): 6000 V _{peak}	
Sampling rate	100 kS/s	Simultaneously at each input
Sampling resolution	16 bit	
Frequency range	DC, 16 Hz to 10 kHz	
Crosstalk attenuation	-60 dB between voltage channels, -95 dB between voltage and current channels	

Current Measurement Inputs (for clip-on current sensors or shunts)

Characteristic	Specification	Note
Quantity	4	Mutually isolated
Connection	Two 4 mm safety sockets each	Red (high), black (low)
Connection options	3xL + N 3xL 2xL + N (two-wattmeter method)	L1, L2, L3, N L1, L2, L3, N calculated L1, L3, N, L2 calculated
Input Impedance	1 MΩ // 5 pF	
Coupling	AC / AC+DC	
Input range	0 to 300 mV / 3 V	Manually selectable
Scaling factors	0 / 0.001 to 99,999 V/V	Individually adjustable for each input
Overload withstand	Continuous: 400 V _{RMS} , transient (1.2/50 μs): 1000 V _{peak}	
Sampling rate	100 kS/s	Simultaneously at each input
Sampling resolution	16 bit	
Frequency range	DC, 16 Hz to 10 kHz	

Frequency measurement

Frequency measurement is conducted individually at each voltage measurement input. System frequency for the 3-phase system, as well as related synchronization of other measuring functions, is specified with priority placed upon voltage measuring channel U1, or automatically upon U2 or U3 in the event of a missing U1 signal.

Measured Quantity	Measuring Range	Resolution	Measuring Uncertainty ±(% rdg. + digits)
Frequency of voltage U (U ≥ 2% of range)	16.00 to 99.99 Hz	0.01 Hz	0.05 +1
	100.0 to 999.9 Hz	0.1 Hz	0.1 +2
	1.000 to 9.999 kHz	0.001 kHz	0.2 +3
	≥10.00 kHz	0.01 kHz	0.5 +5

Voltage measurements#

RMS Voltage U

Selected Range	Measuring Range (CF ≤ 1.4 at U _{max})	Resolution	Measuring Uncertainty ±(% rdg. + % of range)		
			16-65 Hz	DC/65-1000 Hz	1-10 kHz
150 V	1.0 to 150.0 V RMS	0.1 V RMS	0.2 + 0.1	0.4 + 0.2	1 + 0.5
300 V	1.0 to 300.0 V RMS	0.1 V RMS			
600 V	1.0 to 600.0 V RMS	0.1 V RMS			
900 V	1.0 to 900.0 V RMS	0.1 V RMS			

Voltage Waveshape u(t)

Selected Range	Measuring Range	Resolution	Measuring Uncertainty ±(% rdg. + % of range)		
			15-65 Hz	DC/65-1000 Hz	1-10 kHz
150 V	-215.0 to +215.0 V	0.1 V	0.4 + 0.2	0.4 + 0.2	1 + 0.5
300 V	-425.0 to +425.0 V	0.1 V			
600 V	-850.0 to +850.0 V	0.1 V			
900 V	-1275 to +1275 V	1 V			

Harmonic and Inter-harmonic Voltages

Specified measuring uncertainty applies to measuring voltages which exceed 5% of the range. It corresponds to class 1 in accordance with EN 61000-4-7.

Measured Quantity (see table on page 5)	Measuring Range	Resolution	Measuring Uncertainty ±(% rdg. + % of range)	
			h1:16-65 Hz	65-1000 Hz
Absolute amplitude	0.0 to 150.0/.../900.0 V	0.1 V RMS	3 + 0.1	5 + 0.2
Relative amplitude	0.0 to 200.0%	0.1%	t.b.d.	t.b.d.
Phase angle	-179.9° to +180.0°	0.1°	1.0° x h	2.0° x h
	0.0 to 200.0%	0.1%	2%	4%

Current Measurement

RMS Current I

Selected Range	Measuring Range (CF ≤ 1.4 at I _{max})	Resolution	Measuring Uncertainty ±(% rdg. + % of range)		
			16-65 Hz	DC/65-1000 Hz	1-10 kHz
300 mV	0.0 to 300.0 mA RMS	0.1 mA RMS	0.2 + 0.1	0.4 + 0.2	1 + 0.5
3 V	0.000 to 3.000 A RMS	0.001 A RMS			

Current Waveshape i(t)

Selected Range	Measuring Range	Resolution	Measuring Uncertainty ±(% rdg. + % of range)		
			15-65 Hz	DC/65-1000 Hz	1-10 kHz
mV	-425.0 to +425.0 mA	0.1 mA	0.4 + 0.2	0.4 + 0.2	1 + 0.5
3 V	-4.250 to +4.250 A	0.001 A			

Harmonic and Inter-harmonic Currents

Specified measuring uncertainty applies to measuring currents which exceed 5% of the range without current measuring accessories. It corresponds to class 1 in accordance with EN 61000-4-7.

Measured Quantity (see table on page 5)	Measuring Range	Resolution	Measuring Uncertainty ±(% rdg. + % of range)	
			h1:16-65 Hz	65-1000 Hz
Absolute amplitude	0.0 to 300.0 mA RMS	0.1 mA RMS	3 + 0.1	5 + 0.2
	0.0 to 3.000 A RMS	0.001 A RMS	3 + 0.1	5 + 0.2
Relative amplitude	0.0 to 200.0%	0.1%	t.b.d.	t.b.d.
Phase angle	-180.0° to +180.0°	0.1°	1.0° x h	2.0° x h
THD	0.0 to 200.0%	0.1%	2%	4%

MAVOWATT® 50

Energy and Power Disturbance Analyzer

Power Measurement

Active Power, Reactive Power, Apparent Power

Specified measuring uncertainty does not include measuring error of the current measuring accessories.

Measuring Range	Resolution	Measuring Uncertainty ±(% rdg. + digit)	
		16-65 Hz	65-1000 Hz
(range U x Uratio) x (range I x Iratio) Example: (300V x 1V/V) x (3V x 100A/V) = 90,000 W = 90.00 kW	4 decimal places relative to upper range value Example: 0.01 kW	0.5 + 5	t.b.d.

Display

Characteristic	Specification
Type	Color LCD touch-screen, ¼ VGA
Resolution	320 x 240 pixels
Display range	115 x 86 mm
Contrast adjustment	Very bright to very dark
Background illumination	Type CCFL, luminance: typically 80 cd/m²
Display functions	Measurement results, setup menus, status information, operating instructions and measuring circuits

Controls

Characteristic	Specification
Touch-screen	Touch sensitive virtual controls at the display (soft keys) for menu driven instrument operation
4 keys	ON MENU Starts device operation / displays initial menu HELP Displays and hides operating and hookup instructions ESC Returns display to previous menu level PRINT Saves screenshot to USB data storage media
Mains switch	For switching the instrument on and off, with illumination for indicating on-state

Memory

Characteristic	Specification	Note
Data storage media	<ul style="list-style-type: none"> Internal 4 MB flash memory Plug-in compact-flash card Plug-in USB data storage media 	Any desired capacity Any desired capacity
Screenshots	Saves the current screenshot as a bitmap file	Approx. 5 images per MB
Measured data		
Measurement series	Time-triggered, simultaneous saving of up to 1000 measured quantities at intervals of 0.2 seconds to 2 hours	>200,000 measured values per MB
Events data	Measured value triggering for saving selectable events with time stamp, type, phase and measured value	>50,000 events per MB Time resolution: 10 ms
Waveshape	Measured value triggering for saving measuring signals u(t) and i(t) from selectable phases with adjustable sampling rate (10 to 655 µs), duration and pre-trigger	
½-period RMS	Measured value triggering for saving ½-period RMS values Urms _{1/2} and Irms _{1/2} from selectable phases with adjustable storage time and pre-trigger	
Setup profiles		

Master clock

Characteristic	Specification	Note
Type	Real-time clock, quartz controlled	Battery-backed
Time formats:		
Time	hh:mm:ss.00	
Date	DD.MM.YYYY or YYYY-MM-DD or MM/DD/YY	
Time resolution	10 ms	
Accuracy	Max. 5 s per month	

Reference Conditions for Calibration

Characteristic	Specification
Ambient temp.	23 ±2° C
Relative humidity	50 ±10%
Power supply	230 V ±10% or 110 V ±10%
Measuring connection	
Voltage	3-phase, wye (L1-N, L2-N, L3-N, PE-N)
Current	3xL + N (L1, L2, L3, N)
3- voltage asymmetry	<0.1%
Waveshape	Sinusoidal, no DC component
cosφ	1.0

Digital Inputs

Status Inputs

Characteristic	Specification	Note
Quantity	4	Floating, common reference point
Functions	• Display and recording of binary signals	E.g. operating states of machines, equipment and alarm devices
Connection	Plug-in connectors with screw terminals	
DC input signal	Low: < 3 V High: 5 to 24 V (6 mA at 24 V)	S ₀ compatible
Overload withstand	30 V, continuous	

Control Inputs

Characteristic	Specification	Note
Quantity	4	Common grounded reference point
Function	<ul style="list-style-type: none"> Start/stop a recording Synchronization of sampling interval to power utility timing pulse 2 meter inputs for energy measurements with pulses 	
Connection	Plug-in connectors with screw terminals	
DC input signal	Low: < 2 V High: 4 to 5 V (0.5 mA at 5 V)	TTL compatible
Overload withstand	6 V, continuous	

Alarm output

Characteristic	Specification	Note
Quantity	1	
Function	Indication of exceeded limit values for up to 4 measured quantities	Functions as group alarm
Allocation	Freely adjustable measured quantities and limit values	
Connection	Plug-in connectors with screw terminals	
Output signal	Floating relay contact	
Switching capacity	30 V, 1 A	

MAVOWATT® 50

Energy and Power Disturbance Analyzer

Data Interfaces

Ethernet

Characteristic	Specification
Functions	<ul style="list-style-type: none"> Remote control of the instrument via web browser File transfer for measurement and setup files Installation of firmware updates
Type	10/100Base-T (RJ45)
Protocol	TCP/IP, HTTP, FTP

USB Host

Characteristic	Specification
Functions	For connecting data storage media (USB memory stick or hard disk) for: <ul style="list-style-type: none"> Recording measured data, setup profiles and screenshots Installation of firmware updates
Type	USB 2.0 high-speed interface, compatible with USB 1.1

USB Slave

Characteristic	Specification
Functions	<ul style="list-style-type: none"> Remote control of the Instrument File transfer for measurement and setup files
Type	USB 2.0 high-speed interface, compatible with USB 1.1

Power Supply

Characteristic	Specification	Note
Line voltage	85 to 250 V AC/DC	
Line frequency	45 to 400 Hz / DC	
Power consumption	Max. 40 W / 70 VA	
Power failure backup time	>20 minutes with integrated, rechargeable lead-gel battery	After >2 hours charging
Connection	10-A inlet plug with protective contact (IEC 320)	

Electrical Safety

Characteristic	Specification	Note
Safety class	I per EN 61010-1	
Measuring category	CAT IV at 300 V CAT III at 600 V CAT II at 900 V	Per EN 61010-1

Electromagnetic Compatibility

Characteristic	Specification	Note
Interference emission and immunity	Per EN 61326	Complies with EC directive 89/336

Ambient Conditions

Characteristic	Specification	Note
Temperature		
Operation	0 to +40° C (within specification) -10 to +50° C (without damage to device)	Integrated forced air circulation may not be impaired
Storage	-20 to +70°C (-20° C for max. 48 hours)	
Relative humidity		
Storage	Without condensation	After condensation: 2 hours acclimatization time before operation
Operation at 0 to 25° C	Max. 95% , without condensation	
25 to 40° C	Max. 75%	
Elevation		
Operation	Max. 2000 m	
Transport	Max. 12 km	

Mechanical Design

Characteristic	Feature
Type	Portable benchtop device in plastic housing with handle
Protection	Per DIN VDE 0470 T1 / EN 60529
Housing	IP 30
Terminals	IP 20
Carrying case	IP 65
Dimensions	W x H x D
Device	290 x 245 x 140 mm (without handle)
Carrying case	545 x 390 x 240 mm (incl. handle and hinges)
Weight	2.4 kg net (without accessories) 9.2 kg net (incl. carrying case and accessories)

Applicable Regulations and Standards

Standard / Revision	Description
IEC 61010-1 EN 61010-1 VDE 0411-1:2001	Safety requirements for electrical equipment for measurement, control and laboratory use
IEC 60529 EN 60529 VDE 0470-1:2000	Degrees of protection provided by enclosures (IP code)
IEC 60068	Basic environmental testing procedures
VDI/VDE 3540, sheet 2	Reliability of measuring and control equipment Climatic categories for devices and accessories
EN 61326+A1 ... A3 VDE 0843-20:2003	Electrical equipment for measuring technology, control technology and laboratory use – EMC requirements
EN 50160:1999	Voltage characteristics in public electrical power supply systems
EN 61000-4-30: 2003	Procedure for measuring voltage quality
IEC 61000-4-7 EN 61000-4-7 VDE 0847-4-7:2003	Guidelines regarding procedures and devices for the measurement of harmonics and sub-harmonics in power supply systems and interconnected devices
IEC 61000-4-15 EN 61000-4-15 VDE 0847-4-15:2003	Flicker meter – functional description and design specification
DIN 40110 T1/T2	AC quantities in 2-wire/multi-wire electrical circuits
DIN 43864	Electrical interface for pulse transmission between impinging meters and tariff rate devices

MAVOWATT® 50

Energy and Power Disturbance Analyzer

Optional Accessories

Current Measuring Accessories



Type	Figure	Description	Max. Cond. Dia.	Suitable for Appli- cation*)	Meas. Cat.	Nominal Value	Measuring Ranges Usable Range with MAVOWATT 50	Intrinsic Error at Ref. Conditions ±[...% rdg. + ... A]	Output Signal	Article Number
CF3x45	A	C-FLEX flexible AC current sensor, 3-phase set, switchable, 10Hz to 5 kHz, with battery and mains power pack	3x 45 cm circumf.	a, b, c	600 V CAT. III	200 A~ 2000 A~ 20 kA~	5 ... 200 A~ 5 ... 2000 A~ 50 A~ ... 20 kA~	1% + 0.2 A 1% + 2 A 1% + 20 A	10 mV/A 1 mV/A 0.1 mV/A	Z824A
AF033A	B	AmpFLEX flexible AC current sensor, switchable, 10 Hz to 20 kHz, with 9 V battery (operating hours: approx. 150)	45 cm circumf.	(a), b, c	1000 V CAT. III	30 A~ 300 A~	0.5 ... 30 A~ 0.5 ... 300 A~	1% + 0.5 A 1% + 0.6 A	100 mV/A 10 mV/A	Z207A
AF33A	B	AmpFLEX flexible AC current sensor, switchable, 10 Hz to 20 kHz, with 9 V battery (operating hours: approx. 150)	60 cm circumf.	(a), b, c	1000 V CAT. III	300 A~ 3000 A~	0.5 ... 300 A~ 5 ... 3000 A~	1% + 0.6 A 1% + 3 A	10 mV/A 1 mV/A	Z207B
AF101A	B	AmpFLEX flexible AC current sensor, switchable, 10 Hz to 20 kHz, with 9 V battery (operating hours: approx. 150)	120 cm circumf.	(a), b, c	1000 V CAT. III	1000 A~ 10 kA~	5 ... 1000 A~ 50 A~ ... 10 kA~	1% + 3 A 1% + 20 A	1 mV/A 0.1 mV/A	Z207C
AF11A	B	AmpFLEX flexible AC current sensor, 10 Hz to 20 kHz, with 9 V battery (operating hours: approx. 150)	45 cm circumf.	(a), b, c	1000 V CAT. III	1000 A~	5 ... 1000 A~	1% + 3 A	1 mV/A	Z207D
Z821B	C	Clip-on AC current sensor, 30 Hz to 5 kHz	64 mm	a, b, (c)	600 V CAT. II	3000 A~	3 ... 3000 A~	0.5% + 1.5 A	0.33 mV/A	Z821B
Z3512A	D	Clip-on AC current sensor, switchable, 10 Hz to 3 kHz	52 mm	a, b, c	600 V CAT. III	1 A~ 10 A~ 100 A~ 1000 A~	0.001 ... 1.2 A~ 0.01 ... 120 A~ 0.1 ... 120 A~ 1 ... 1200 A~	0.7 ... 3% + 0.001 A 0.5 ... 1% + 0.002 A 0.2 ... 1% + 0.02 A 0.2 ... 1% + 0.2 A	1000 mV/A 100 mV/A 10 mV/A 1 mV/A	Z225A
WZ11B	G	Clip-on AC current sensor, switchable, 30 Hz to 500 Hz	20 mm	a, (c)	600 V CAT. III	20 A~ 200 A~	0.5 ... 20 A~ 5 ... 200 A~	1 ... 3% + 0.05 A 1 ... 3% + 0.5 A	100 mV/A 10 mV/A	Z208B
Z13B	E	Active AC/DC clip-on current sensor, switchable, DC to 10 kHz, with 9 V battery (operating hours: approx. 50)	50 mm	b, c	300 V CAT. IV.	40 A~/60 A~ 400A~/600A~	0.2 ... 40 A~/60 A~ 0.5... 400 A~/600A~	1.5% + 0.5 A	10 mV/A 1 mV/A	Z231B
Z201A	F	Active AC/DC clip-on current sensor, switchable, with 9 V battery (operating hours: approx. 30)	19 mm	b, c	300 V CAT. III	20 A~/30 A~	0.01... 20 A~/30 A~	1% + 0.01 A	100 mV/A	Z201A
Z202A	F	Active AC/DC clip-on current sensor, switchable, DC to 10 kHz, with 9 V battery (operating hours: approx. 50)	19 mm	b, c	300 V CAT. III	20 A~/30 A~ 200A~/300A~	0.1 ... 20 A~/30 A~ 1 ... 200 A~/300 A~	1% + 0.03 A 1% + 0.3 A	10 mV/A 1 mV/A	Z202A
Z203A	F	Active AC/DC clip-on current sensor, switchable, DC to 10 kHz, with 9 V battery (operating hours: approx. 50)	31 mm	b, c	300 V CAT. III	200A~/300A~ 1 kA~/1 kA~	1 ... 200 A~/300 A~ 1 ... 1000A~/1000A~	1% + 0.5 A	1 mV/A	Z203A
Z860A	H	Plug-in shunt 50 Ω, 0.2%, 1.5 W	-	a, b	600 V CAT. III	20 mA	50 μA ... 20 mA	0.2%	50 mV/mA	Z860A
Z861A	H	Plug-in shunt 1Ω, 0.2%, 1.5 W	-	a, b	600 V CAT. III	1 A	1 mA ... 1.2 A	0.2%	1000 mV/A	Z861A
Z862A	H	Plug-in shunt 0.05 Ω, 0.2%, 1.5 W	-	a, b	600 V CAT. III	5 A	0.02 ... 6 A	0.2%	50 mV/A	Z862A
Z863A	H	Plug-in shunt 0.01 Ω, 0.2%, 1.5 W	-	a, b	600 V CAT. III	16 A	0.1 ... 16 A	0.2%	10 mV/A	Z863A

*) a = Long-Term measurement

b = Harmonic measurement

c = Frequency converter measurement

MAVOWATT® 50

Energy and Power Disturbance Analyzer

Standard Equipment

- 1 MAVOWATT 50 energy and power disturbance analyzer
- 1 set of cables for voltage measurement inputs including 4 pairs of measurement cables (length: approx. 2 m) with test probe and plug-on alligator clips
- 3 short measurement cables with 4 mm safety plugs (stackable) for bridging measurement inputs
- 1 power cable with protective contact plug and inlet plug
- 1 USB-A interface cable
- 1 Ethernet interface cable
- 1 stylus pen
- 1 carrying case for instrument and accessories
- 1 set of operating instructions
- 1 CD ROM with latest operating instructions, technical data sheet and respectively measuring notes

Order Information

Description	Type Designation	Article Number
3-phase energy and power disturbance analyzer with carrying case, set of measurement cables, USB cable, crossed Ethernet cable and operating instructions	MAVOWATT 50	M816A
See page 11 for current measuring accessories .		

Training

We offer interesting seminars with practical experience, held in German, for many of our products.

The seminar entitled *“Power Disturbance Analysis, Power Analysis and Energy Analysis with the MAVOWATT 50”* (course no. GTT 1641) can also be held on-site at your facility, and in English if desired. Instrument and software operation and functions are treated in detail with the help of practical, hands-on exercises.

Please request our seminar schedule if required.



Printed in Germany • Subject to change without notice

GMC-I  **GOSSEN METRAWATT**
GMC-I Gossen Metrawatt GmbH
Thomas-Mann-Str. 16-20
90471 Nuremberg • Germany

Phone +49-(0)-911-8602-0
Fax +49-(0)-911-8602-669
E-mail info@gossenmetrawatt.com
www.gossenmetrawatt.com